

Control Equipment for Electric Screens

Integrated Screen Control



Product Features

Da-Lite's Integrated Screen Control (ISC) solutions are designed to fit the needs of systems requiring advanced projection screen control. This industry leading technology offers greater flexibility for Systems Integrators and Information Technology professionals.

Whether control needs are basic functionality, up, stop down, or more advanced, the ISC line can manage these needs based on its RS-232 serial control capabilities. ISC can be expanded to include Ethernet control, allowing operation from a standard web browser and the ability to pass serial communication through almost any existing LAN or WAN environment.

These Integrated Screen Control solutions are designed using a building block approach with the foundation in RS-232 control. This multi-tiered solution allows for greater flexibility and the deployment of screens in multi conference room facilities.

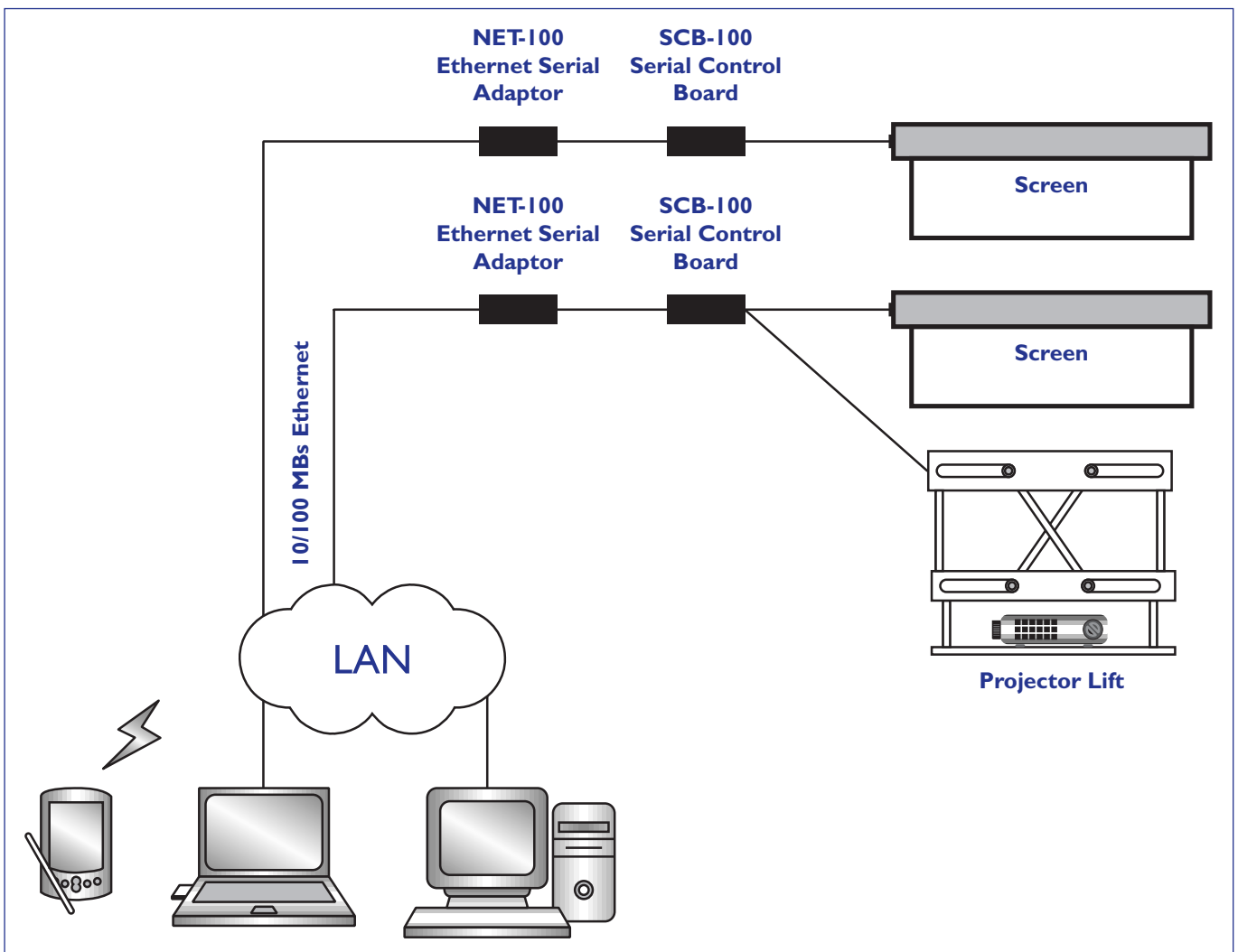

Control Equipment for Electric Screens

Serial Control Board - SCB-100



Product Features

The SCB-100 allows for control over a screen using RS-232 communication and / or relay closures. Designed for the simplest to most sophisticated system installations, a single Serial Control Board provides control over any single motor screen, masking screen or projector lift.

The Serial Control Board is available as a factory installed option inside the Contour screens or in an external enclosure with legacy screen and projector lift models.

Specifications:

I/O Ports:

- RS-232 Port 1 (normally used for the Da-Lite Ethernet Serial Adaptor)
- RS-232 Port 2 (normally used for a third party control system)
- Contact Closure (Relay 1), 3-button wall switch included
- Contact Closure (Relay 2)
- Peripheral Power: 12VDC, 500mA

Termination Type: Captive Screw Terminals

Power Requirements: 100-240VAC, 50 or 60 Hz

Fused Power: 10A

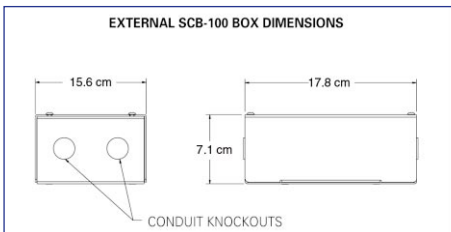
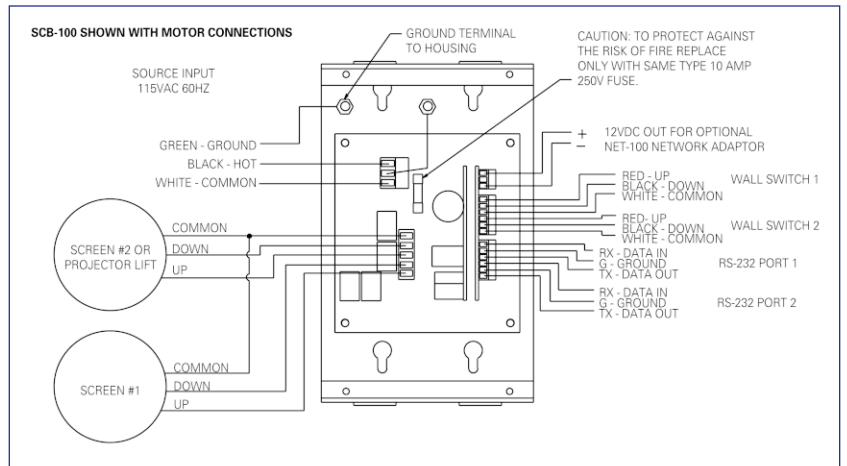
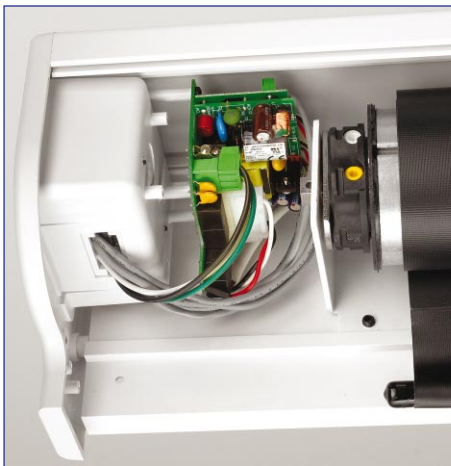
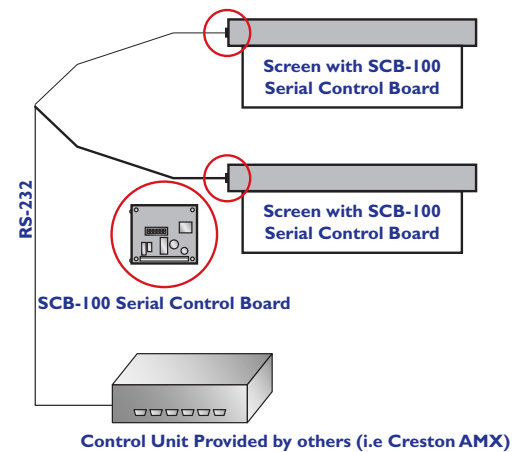

Distributed By:



Control Equipment for Electric Screens

Ethernet Serial Adaptor - NET-100



Product Features

The Ethernet Serial Adaptor allows any SCB-100 enabled screen to be controlled over a local area or wide area network. Using standard TCP/IP protocol and a 10Base-T connection, the NET-100 can be easily integrated into almost any existing local area network. With a built-in web server, a screen may be accessed from any web browser software, such as Microsoft® Internet Explorer, for control and status information. SCB-100 required for use.

Specifications:

I/O Ports:

- RS-232 (used to communicate with SCB-100)
- 10Base-T, RJ-45 Ethernet jack

IP Addressing: Static

Termination Type: Captive Screw Terminals

Power Requirements: 12VDC, 300mA (provided through connection to SCB-100)

Required Accessories: SCB-100 Serial Control Board

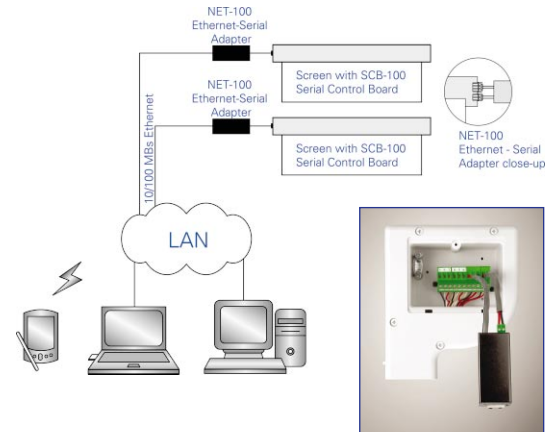

Remote Control Kit - Infrared

Product Features

- Suitable for all Da-Lite and Gilkon electric screens
- Three button system - up, down or stop commands
- Australian approvals

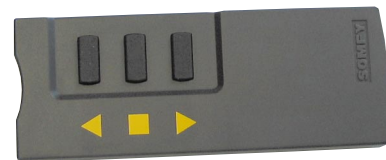

Remote Control Kit - Radio Frequency

Product Features

- Suitable for all Da-Lite and Gilkon electric screens
- Three button system - up, down or stop commands
- No "Line of Sight" signal issues
- Australian approvals



Distributed By:



Control Equipment for Electric Screens Single Motor Low Voltage Control (LVC)



Product Features

- CE and C tick approvals
- Use a low voltage control system to operate screen motor
- Multiple switches can be utilised when wired in parallel



Da-Lite Projector Interface Unit

Product Features

- 5 Volt or 12 volt signal from projector will automatically raise or lower the screen when the projector is on or off
- Kit includes manual operation switch
- Projector must have a 12 volt or 5 volt lead to operate the interface

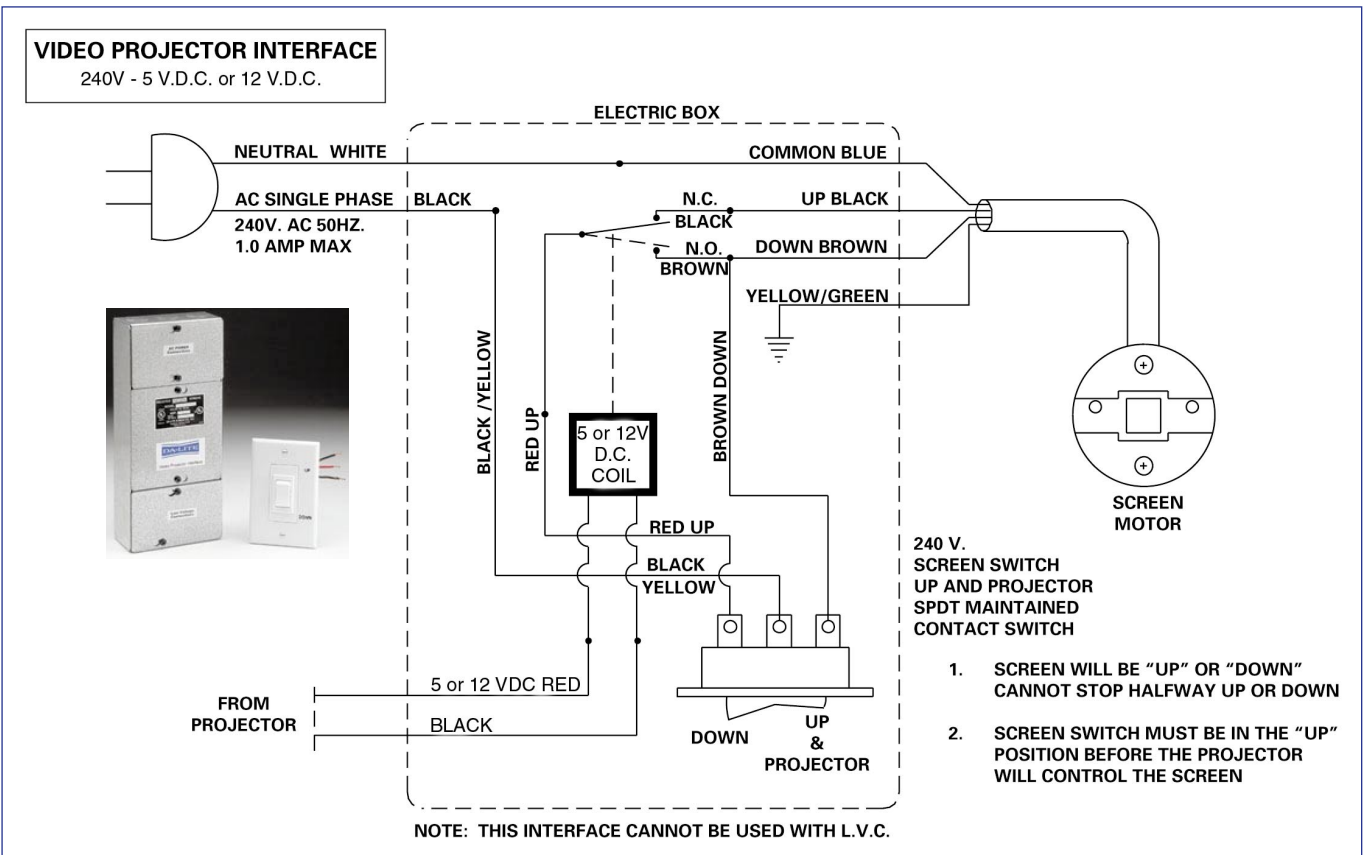

Distributed By:

